

TOP VIEW

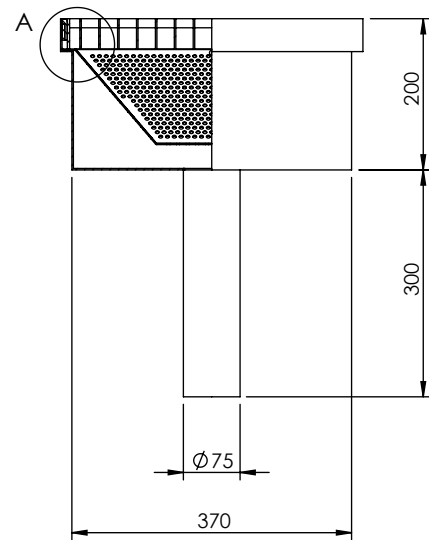

FRONT VIEW

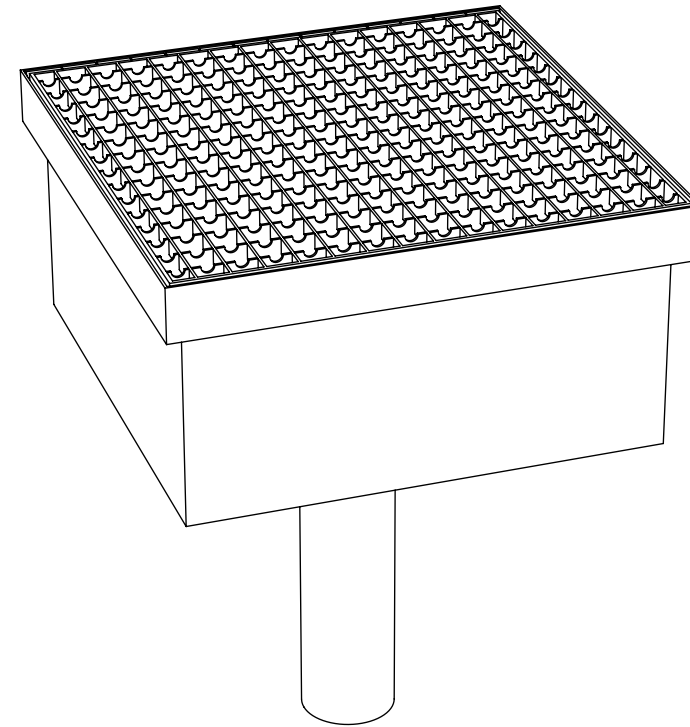
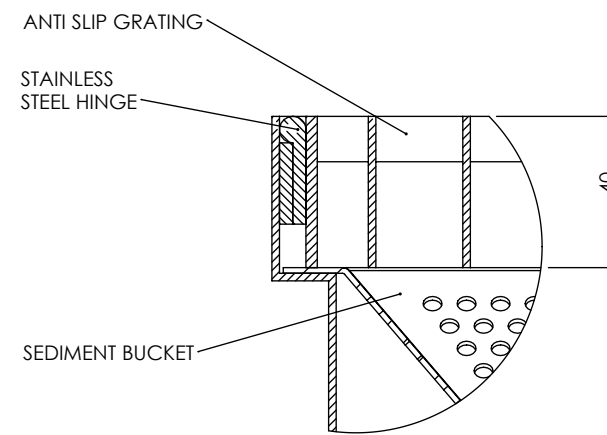

DETAIL A
SCALE 1 : 2



59-62 BRINDLEY ROAD
ASTMOOR INDUSTRIAL ESTATE
RUNCORN, CHESHIRE WA7 1PF
TEL: 01928 563532
FAX: 01928 580224

THIS DRAWING REMAINS THE PROPERTY OF ALULINE GROUP AND MAY NOT BE COPIED, REPRODUCED, LENT OR DISCLOSED WITHOUT THEIR EXPRESS PERMISSION.

ALULINE GROUP RESERVE THE RIGHT TO MAKE A CHARGE FOR DRAWING/S

PROJECTION

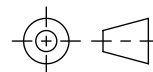

DIMENSIONS IN MILLIMETERS (mm)

DRAWN BY: ctorralba

DATE: 29.04.2009

TITLE:

Parking Floor Drain

DRAWING NO.

DU-1003

SCALE:

1:10 @ A3

REV

?